

5Hz to 1MHz
WIDE RANGE FULLY AUTOMATIC
DISTORTION ANALYZER

MODEL 6900B SERIAL NO. _____

**OPERATING AND MAINTENANCE
MANUAL**



北京泰瑞恩商贸有限公司
Beijing Torion Trading Co.Ltd.

www.torion.cn
sales@torion.cn

电话: 13801253818
传真: 010-84067150



Unit 4, 15 Jonathan Drive, Brockton, MA 02301-5566
Tel: (508) 580-1660; Fax: (508) 583-8989

TABLE OF CONTENTS

1.0	GENERAL DESCRIPTION	1-1
1.1	Introduction	1-1
1.2	Specifications	1-1
1.3	General Specification	1-3
2.0	OPERATION	2-1
2.1	Introductions	2-1
2.2	Power Requirements.....	2-1
2.3	Turn-on Procedure.....	2-1
2.4	Controls, Terminals, Indicators.....	2-1
2.5	Operation	2-2
2.6	Optional Features	2-4
3.0	INCOMING ACCEPTANCE	3-1
3.1	Introduction	3-1
3.2	Procedure	3-1
4.0	CIRCUIT DESCRIPTION.....	4-1
4.1	Introduction	4-1
4.2	Circuit Description.....	4-1
5.0	CALIBRATION	5-1
5.1	Introduction	5-1
5.2	Calibration Procedure.....	5-1
5.3	Power Supply	5-1
5.4	Voltmeter Calibration.....	5-2
5.5	Input Amplifier Calibration.....	5-3
5.6	Stepping Amplifier Calibration	5-3
5.7	Output Amplifier Calibration	5-3
5.8	Frequency Detector Calibration.....	5-4
5.9	1kHz Oscillator Calibration.....	5-4
5.10	1kHz Calibration	5-4
5.11	Integrator Level Calibration	5-4
5.12	Calibration Adjustments.....	5-4
6.0	MAINTENANCE	6-1
6.1	Introduction	6-1
6.2	Trouble-Shooting Procedure.....	6-1
6.3	Step-by-Step Troubleshooting procedure.....	6-1
6.4	Power Supply	6-6
6.5	ALC Amplifier	6-6
6.6	Null Amplifier	6-7
6.7	Meter Amplifier	6-7
6.8	Operational Rectifier	6-7
6.9	Integrator.....	6-8
6.10	Voltage Discriminator	6-8
6.11	Frequency Discriminator.....	6-8
6.12	Oscillator	6-8
7.0	PARTS LISTS, SCHEMATICS AND BOARD LAYOUTS	7-1
7.1	Ordering Information	7-1
7.2	Ordering Unlisted Parts	7-1

Model 6900B



Figure 1.1 Model 6900B

SECTION 1

GENERAL DESCRIPTION

1.1 INTRODUCTION

The Krohn-Hite Model 6900B, illustrated in Figure 1.1, is a Fully Automatic Distortion Analyzer designed for ultra-low distortion and ac voltage measurements in the 5Hz to 1MHz frequency range. The Distortion Analyzer will measure total harmonic distortion (THD) down to 0.005%, typically, with 0.001% resolution. A unique Auto Set Level feature eliminates the need to manually preset the input reference level before each measurement for any input voltage between 0.1-130 volts rms. An Auto-Null Network provides Auto Nulling of the fundamental frequency over the entire frequency range. The Analyzer also measures ac voltages from 10mV to 130 volts rms over the range of 5Hz to 1MHz.

The Auto-Ranging Digital Display Meter (DDM) reads directly in percent distortion or ac volts, and eliminates the ambiguities commonly found in analog voltmeter. A 1kHz ultra-low distortion (0.003%) sinewave output is provided for use as a stimulus to test circuit or system distortion characteristics, or for self-checking of the Analyzer.

A switch selectable High-Pass filter reduces the effects of hum and low frequency noise. The 400Hz, 30kHz and 80kHz selectable filters are effective only in the DISTORTION MODE. An internal low-pass tracking filter eliminates high frequency noise when making low distortion measurements.

A DISTORTION OUTPUT is also provided for visual inspection or spectral analysis of the input signal after the fundamental has been filtered out.

An optional BCD output is available.

1.2 SPECIFICATIONS

1.2.1 DISTORTION METER SPECIFICATIONS

- 1.2.1.1 FUNDAMENTAL FREQUENCY RANGE:** 5Hz to 1MHz automatically tuned over the entire specified input frequency range. An intermittent display indicates an out-of-range condition.
- 1.2.1.2 INPUT:** No presetting required over input level from 100mV to 130 volts rms. Impedance; 110k ohms shunted by 100pF.
- 1.2.1.3 DISTORTION RANGE:** A digital panel meter with Auto-Ranging displays percentage of total harmonic distortion (THD) to 19.9%.

Measurement (%)	Resolution (%)
0.000 - .100	0.001
0.10 - 2.00	0.01
2.0 - 19.9	0.1

1.2.2 DISTORTION MEASUREMENT ACCURACY

- 1.2.2.1 Input volts:** 0.1 – 0.25
- 1.2.2.2 Distortion levels:** >0.01%
- 10Hz to 50kHz: $\pm 15\%$ of reading or 0.01%, whichever is greater.
- 5Hz to 100kHz: $\pm 15\%$ of reading or 0.02%, whichever is greater.
- 100kHz to 500kHz: $\pm 15\%$ of reading or 0.1%, whichever is greater.
- 500kHz to 1MHz: $\pm 25\%$ of reading or 0.5%, whichever is greater.

1.2.2.3 Input volts: 0.25 – 130

1.2.2.4 Distortion levels: >0.005%

10Hz to 50kHz: $\pm 15\%$ of reading or 0.005%, whichever is greater.

5Hz to 100kHz: $\pm 15\%$ of reading or 0.01%, whichever is greater.

100kHz to 500kHz: $\pm 15\%$ of reading or 0.05%, whichever is greater.

500kHz to 1MHz: $\pm 25\%$ of reading or 0.5%, whichever is greater.

1.2.3 RESIDUAL DISTORTION AND NOISE

1.2.3.1 Input: 0.1V – 0.25V

5Hz to 1MHz; less than 0.03% from 5Hz to 50kHz rising to 0.5% at 1MHz.

1.2.3.2 Input: 0.25V – 130V

50Hz to 20kHz; less than 0.01%

5Hz to 1MHz; less than 0.02% from 5Hz to 50kHz rising to 0.5% at 1MHz.

1.2.4 SETTling TIME (to 0.1% THD): Typically less than 3 seconds from 50Hz to 1mHz. Longer at lower frequencies.

1.2.5 FUNDAMENTAL REJECTION: Greater than 10dB below residual THD.

1.2.6 FILTERS

400Hz High Pass: - 3dB at 400Hz $\pm 10\%$; 40db/decade rolloff.

30kHz Low Pass: -3dB at 30kHz $\pm 5\%$; 60db/decade rolloff.

80kHz Low Pass: - 3dB at 80kHz $\pm 5\%$; 60db/decade rolloff.

1.2.7 DISTORTION OUTPUT (Residual signal after fundamental is nulled): Voltage; 100mVrms/%THD. Impedance; less than 500 ohms.

1.2.8 ANALOG OUTPUT: 100mVdc/%THD. Impedance; less than 1k ohms.

1.2.9 DIGITAL DISPLAY METER (DDM): Three digit meter with Auto-Ranging.

1.2.10 AC VOLTMETER SPECIFICATIONS

1.2.10.1 Frequency Range: 5Hz to 1MHz.

1.2.10.2 Voltage Range: 0.01V to 130 volts rms.

Voltage Range	Resolution (volts)
0.01 – 1	0.001
1 – 10	0.01
10 – 130	0.1

1.2.10.3 Accuracy: $\pm 2\% \pm 1$ digit from 10Hz to 500kHz, $\pm 5\% \pm 1$ digit from 5Hz to 1MHz over specified voltage range.

1.2.11 DIGITAL DISPLAY METER: Three digit meter with Auto-Ranging.

1.2.12 INPUT IMPEDANCE: 110k ohms shunted by 100pf.

1.2.13 OSCILLATOR OUTPUT

1.2.13.1 Frequency: 1kHz, fixed.

1.2.13.2 Output (rms): 5 volts at 3 milliamperes maximum.

1.2.13.3 Distortion: 0.003%.

1.2.13.4 Impedance: 600 ohms.

1.3 GENERAL SPECIFICATIONS**1.3.1 FRONT PANEL CONTROLS**

MODE switch for selecting either voltmeter (VOLTS) or distortion (% DIST) operation.
FILTER switch for selecting 400Hz High Pass, 30kHz and 80kHz Low Pass operation.
POWER switch.

1.3.2 REAR PANELS

Switches for selecting 120V/240V ac operation and normal or low (NORM/LOW) as line voltage.

1.3.3 CONNECTORS (BNC)

Front panel: INPUT, 1kHz OUTPUT and DISTORTION OUTPUT
Rear panel: INPUT, ANALOG OUTPUT

1.3.4 MAXIMUM DC COMPONENT: 100V.

1.3.5 ISOLATION TO CHASSIS: 500Vdc.

1.3.6 OPERATING TEMPERATURE RANGE: 0°C to 45°C.

Unless otherwise noted, specifications apply at 25°C ±5°C.

1.3.7 POWER REQUIREMENTS: Switch selectable, 90-110, 10-8-132, 180-220 or 216-264 volts, single phase, 50-400Hz, 15 watts.

1.3.8 DIMENSIONS AND WEIGHTS: 16.625"/42.3cm wide, 3.5"/9cm high, 14.375"/37.5cm deep, 13.5lb/6.1kg. An optional rack-mounting kit, Part No. RK-319, is available for installing the unit in a standard 19" rack.

1.3.9 BCD OUTPUT (optional): Provides 13 lines of parallel BCD output, plus 1 MODE output, 3 decimal point outputs and 4 separate 3-state control lines. Compatible with DTL, RTL and TTL logic.

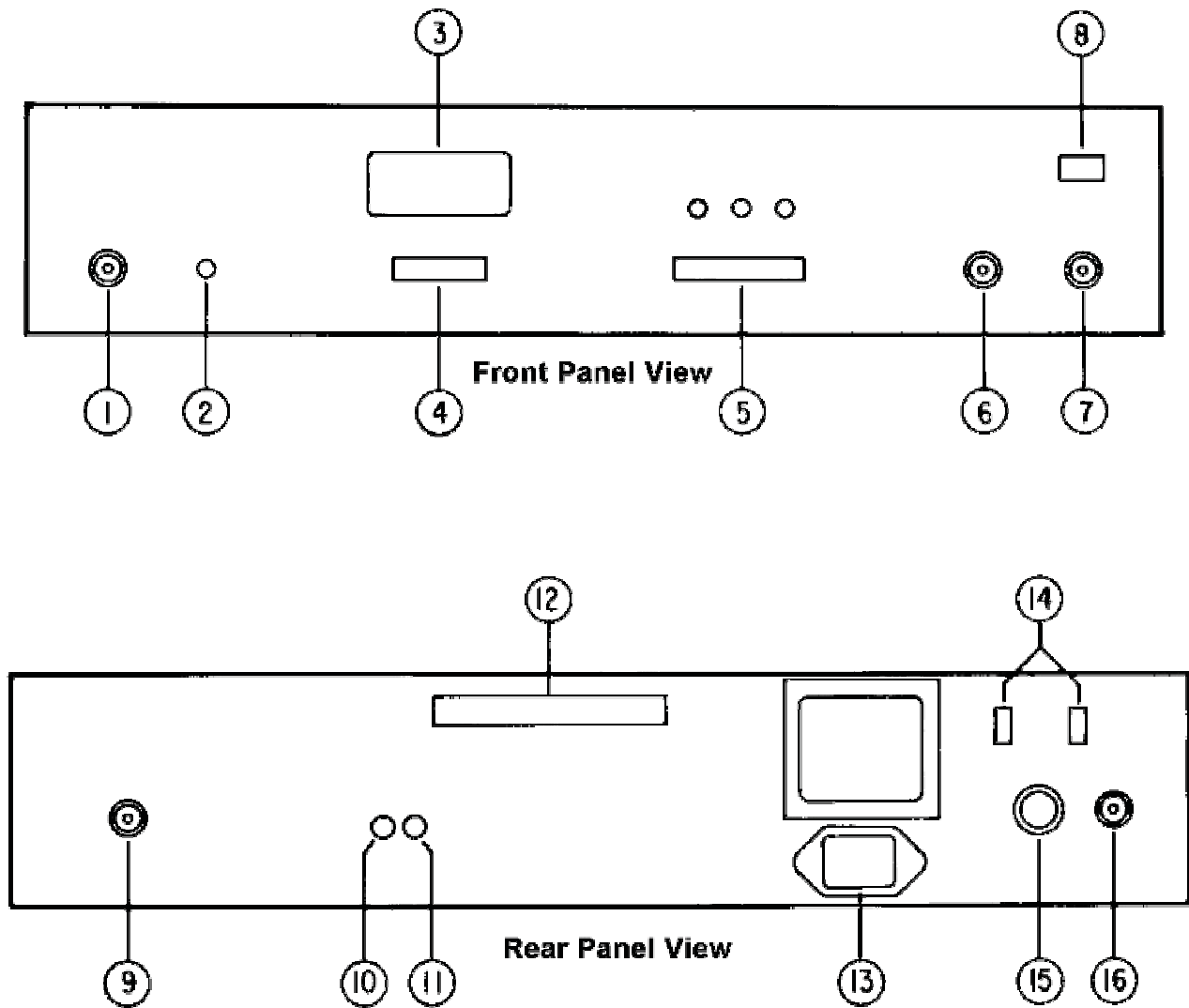

Figure 1.2 Operating Controls, Connectors and Display

SECTION 2 OPERATION

2.1 INTRODUCTION

This section describes the basic operation of the Model 6900B. It includes the proper ac power requirements, the recommended turn-on procedure and a detailed explanation of all operating controls, modes of operation and special optional features.

2.2 POWER REQUIREMENTS

The Model 6900B is designed to operate from a single phase, 50-400Hz ac power source of 90-110, 108-132, 180-220, or 216-264 volts. Line switches allow the 6900B to be powered from one of the above 4 voltage ranges. The ac power receptacle is a standard 3-pin connector, and complies with the European I.E.C. standard. A detachable 3-wire line cord is provided with the instrument. A 3/8A slow blow fuse should be inserted in the fuse receptacle.

2.3 TURN-ON PROCEDURE

- 2.3.1** Set the line switches for the correct voltage range. For 90-110 volts, set the voltage range to 120V and the NORM/LOW switch to Low. For 108-132 volts, set the voltage range to 120V and the NORM/LOW switch to Normal.

For 180-220 volts, set the voltage range to 240V and the NORM/LOW switch to Low.

For 216-264 volts, set the voltage range to 240V and the NORM/LOW switch to Normal.

- 2.3.2** Make sure the POWER switch is in the off position.

- 2.3.3** Plug the line cord into the unit and into an ac outlet.

WARNING!

The chassis of this instrument is connected to ground. For safety purposes, connect the line cord to a grounded, 3 terminal ac outlet.

- 2.3.4** Turn the POWER switch on, and allow the unit to warm up for several minutes.

CAUTION!

Because of the potentially dangerous voltages that exist within the unit, the cover of this instrument should not be removed when the instrument is connected to an ac power source.

2.4 CONTROLS, TERMINAL, INDICATORS

2.4.1 FRONT PANEL:

- 2.4.1.1 INPUT:** Input voltage; 100mV to 130 volts rms in PERCENT DISTORTION MODE, 10mV-130V rms in VOLT MODE. Input impedance; 110k ohms shunted by 100pf. Maximum dc; $\pm 100V$. Isolation to chassis; 500Vdc.
- 2.4.1.2 INPUT LEVEL:** LOW LED indicates when the input, in the DISTORTION MODE, is below the minimum level of 100m Vrms.

- 2.4.1.3 **DIGITAL DISPLAY METER (DDM):** Displays directly in percent distortion or ac volts.
 - 2.4.1.4 **MODE:** Pushbutton switch for mode of operation either percent distortion (% DIST) or ac volts (VOLTS).
 - 2.4.1.5 **FILTER:** There are three switch selectable filters: 40dB/decade, 400Hz, HIGH PASS, for reducing the affects of line (to be used at input frequencies greater than 1kHz); 60dB/decade, 30kHz, LOW PASS, which provides band limiting required by FCC for proof of performance broadcast testing; 60dB/decade, 80kHz, LOW PASS, for reducing high frequency noise.
 - 2.4.1.6 **1kHz OUTPUT:** 1kHz, fixed sinewave output, 5 volts rms at <0.003% distortion. Output impedance; 600 ohms. Maximum output current; 3mA rms. May be used as a standard to test linearity of components system distortion characteristics or performance of the 6900B.
 - 2.4.1.7 **DISTORTION OUTPUT:** AC voltage for visual inspection of the input signal with the fundamental removed. Approximately 100mV rms/% THD.
 - 2.4.1.8 **POWER:** Pushbutton on-off switch.
- 2.4.2 **REAR PANEL:**
- 2.4.2.1 **ANALOG OUTPUT:** DC voltage proportional to distortion; 100mV/%, BNC.
 - 2.4.2.2 **R761:** Screwdriver null adjust to obtain maximum capability at low distortion levels.
 - 2.4.2.3 **R786:** Screwdriver null adjust to obtain maximum capability at low distortion levels.
 - 2.4.2.4 **BCD OUTPUT (optional):** Includes 13 lines of parallel BCD output, 1 MODE output, 4 decimal point outputs, 4 separate 3-state control lines and 1 programming ground return for a total of 23 lines. An edge connector is supplied.
 - 2.4.2.5 3-wire ac receptacle.
 - 2.4.2.6 **LINE:** Slide switches for 120 or 240 volt operation and normal or low line conditions.
 - 2.4.2.7 AC line fuse receptacle.
 - 2.4.2.8 **INPUT:** In parallel with front panel INPUT.

2.5 OPERATION

2.5.1 CONDITIONS WHICH MAY AFFECT THE ACCURACY OF THE DISTORTION OR VOLTAGE MEASUREMENT:

- 2.5.1.1 To minimize the effects of line voltage and low frequency noise when the fundamental is greater than 1kHz, a switch selectable FILTER is provided, which has a low frequency cutoff at approximately 700Hz, and an attenuation rate of 12dB/octave.

An internal low pass tracking filter eliminates the effects of higher order noise when the total harmonic distortion being measured is less than 0.1%. The filter has an attenuation rate of 6dB/octave. Its 3dB cutoff is approximately 10 times the fundamental frequency. When the distortion level is less than 0.1%, the filter is automatically switched in.

- 2.5.1.2** The presence of a spike, glitch or transient of the signal, will show up on the distortion reading. In most cases, any discrepancies in distortion readings between the Krohn-Hite Distortion Analyzer and another analyzer may be due to the other analyzer's inability to detect the spike or transient.
- 2.5.1.3** Another source of error is the proximity of other electronic equipment to the Analyzer. When making distortion measurements, do not place or stack other test equipment on top of the Analyzer. The equipment may generate an electromagnetic field of sufficient magnitude to create serious error in the reading at low distortion levels.
- 2.5.1.4** Always use the Analyzer with its cover in place and secured. This not only shields the Analyzer circuit from unwanted interference, but most importantly, it also prevents injury from ac voltages within the unit.

2.5.2 DISTORTION MEASUREMENTS

The Model 6900B is designed to measure the total harmonic distortion (THD) of a waveform with a fundamental frequency between 5Hz and 1MHz and amplitude between 100mV and 130 volts rms. The Distortion Analyzer will measure as low as 0.005%, typically, and up to 19.5%. The THD is displayed directly as a percentage of the fundamental by the front panel Digit Display Meter (DDM), which incorporates an Auto-Ranging feature to provide increased resolution at low distortion levels.

The Analyzer is automatically tuned to the fundamental frequency by means of an Auto-Null network.

- 2.5.2.1** To measure distortion, proceed as follows:
- Set the MODE switch to "% DIST" position.
 - Connect the signal to be measured to the front panel BNC labeled INPUT. There is no need to manually preset a reference level. The 6900B will automatically preset its input reference level for any amplitude between 100m V and 130 volts rms. If the input amplitude falls below the required level, the front panel LOW indicator will signal the out-of-range condition. The input amplitude should then be adjusted until the indicator goes off.
 - The DDM will then display the total harmonic distortion directly in percent.

2.5.3 AC VOLTAGE MEASUREMENTS

As an ac voltmeter, the 6900B will measure the rms voltage of an input wave form between 10 millivolts and 130 volts rms over the Analyzers frequency range of 5Hz to 1MHz.

- 2.5.3.1** To measure ac voltage:
- Press the "VOLTS" button.
 - Connect the waveform to the front panel BNC labeled INPUT. There is no manual presetting required.
 - The ac voltage is displayed in volts by the Auto-Ranging Digital Display Meter.

2.5.4 DISTORTION OUTPUT

As an aid to further analysis, the distortion signal is made available at the front panel DISTORTION OUTPUT and corresponds to approximately 100mV rms per 1% distortion. The DISTORTION OUTPUT may be connected to an oscilloscope to create a Lissajous patten, or may be connected to a Spectrum or Wave Analyzer for measurement of the individual harmonic amplitudes.

2.5.5 ANALOG OUTPUT

The ANALOG OUTPUT may be used with a recorder or plotter. It provides a dc voltage of approximately 100mV/1% of the displayed distortion.

2.5.6 1kHz OUTPUT

The 1kHz OUTPUT is a fixed, 1kHz low distortion, 0.003%, sinewave for use as a stimulus to measure the distortion characteristics of another circuit or system or to self-check the Analyzer. The output amplitude is 5 volts rms with an output impedance of 600 ohms.

2.5.7 PERIODIC ADJUSTMENT OF 1kHz INTERNAL DISTORTION

To obtain maximum capability at low distortion levels, it is advisable to periodically adjust R761 and R786 on the rear panel.

After a 15-20 minute warm-up period, connect the Analyzer's 1kHz OUTPUT to its INPUT. Place the MODE switch to "% DIST". Then, alternating between R761 and R786, adjust for the lowest distortion reading on the DDM (typically 0.003%).

2.5.8 FILTERS

The 400Hz, 30kHz and 80kHz selectable FILTERS are effective only in the DISTORTION MODE.

- a. The 400kHz HIGH PASS FILTER has an attenuation rate of 40dB/decade and may be used to suppress low frequency noise. It should be used when the input frequency setting is above 1kHz.
- b. The 30kHz and 80kHz LOW PASS FILTERS may be used to either suppress high frequency noise or to provide a controlled bandwidth during distortion measurements.

2.6 OPTIONAL FEATURES

Option 001, BCD Output: This option provides an equivalent BCD output of the front panel DDM, 4 additional control lines and a programming ground return. The logic levels are compatible with DTL, RTL, TTL, and CMOS logic.

Each digit of the DDM, with the exception of the 100's digit, is represented by 4 data output lines coded in a 1-2-4-8 format, pins 4-15 of the DDM. The 100's digit is represented by a single output line, pin 3.

The mode output line, pin 1, indicates when the Mode switch is in the "% Dist" or "Volts" position. The output logic level remains "high" for volts and switches to its "low" state for percent distortion.

The decimal point output, pins B, F, and N, indicate the location of the decimal point in the DDM. A "high" state on B, F or N indicates that respective decimal point is on.

The 4 remaining control lines labeled "3-state control", pines J, K, L and M, provide a disable function for each digit. The "3-state control" refers to the 3 position states of the data output lines. When the control lines are left "low" or open-circuit, the 4 data lines and the decimal point line for that digit will be enabled. These lines will be "high" or "low" depending on the digits displayed. The source impedance of the output lines is low during the enable state. When the control lines are pulled "high", transfer of data will be inhibited. All output lines disabled will be at zero output level and exhibit a high source impedance. The advantage of this "3-state control" is that it allows the user to externally reconnect the data output lines for serial or multiplex operation, without the need for buffer stages.

Figure 2.1 lists the programming pin connections for this option. A programming edge connector is provided.

Pin	Function	Description
1	Mode	“low for “% DIST” “high” for “VOLTS”
2	N/C	
3	1000	
4	0800	
5	0400	
6	0200	DPM
7	0100	
8	0080	BCD
9	0040	
10	0020	OUTPUT
11	0010	
12	0008	
13	0004	
14	0002	
15	0001	
A	N/C	
B	X.XXX	Decimal Point
C	N/C	
D	N/C	
E	N/C	
F	XX.XX	Decimal Point
H	N/C	
J	1XXX 3-state	“high” for “high Z”
K	X1XX 3-state	“low” or open circuit
L	XX1X 3-state	For “enable”
M	XXX1 3-state	
N	XXX.X	Decimal Point
P	N/C	
S	GND	Programming Ground

BCD, MODE and Decimal Point Output Levels:
 $V_{oh}=2.5V$, $I_{source}=-4.2mA$; $V_{ol}=0.4V$, $I_{sink}=2.1mA$

Disable Input Levels:
 $V_{oh}>3.5V$, $R_{load}=47k\Omega$; $V_{ol}<1.5V$, $R_{load}=47k\Omega$

Figure 2.1 BCD Output Pin Connection

This page intentionally left blank.

SECTION 3 INCOMING ACCEPTANCE

3.1 INTRODUCTION

The following procedure may be used to verify that the Distortion Analyzer is operating within specifications, both for incoming inspection and routine servicing. Tests should be made with the unit at operating temperature, the covers secured in place, and the procedure given below followed in sequence. Familiarize yourself with the initial set-up and operating procedure as out lined in Section 2, Operation.

CAUTION

Because of the potentially dangerous voltages that exist within the unit, the covers should not be removed when the instrument is connected to an ac power source.

3.2 PROCEDURE

3.2.1 PRELIMINARY SET-UP

For equipment required, see Section 5.2. After the Analyzer has been connected to a suitable ac power source (see Section 2.3) connect the Analyzer’s 1kHz OUTPUT to both the Analyzer’s INPUT and to the scope’s external horizontal input. Set the MODE switch to “% DIST”. Connect a 0.1µf capacitor across the DISTORTION OUTPUT, and connect the DISTORTION OUTPUT to the scope’s vertical input. Set the input sensitivity to 1mV/cm, ac coupled. Adjust the scope’s horizontal control to obtain approximately a 6 cm sweep.

Adjust R761 and R786, if necessary, on the rear panel, for a closed, flat ellipse. Remove the 0.1µf capacitor from the DISTORTION OUTPUT and disconnect the 1kHz OUTPUT from the Analyzer’s INPUT.

3.2.2 LOW DISTORTION CHECK

Connect an Ultra-Low Distortion Oscillator (Krohn-Hite Model 4400A or equivalent for measurements from 10Hz to 100kHz and Model 4200B or equivalent for measurements from 500kHz to 1MHz) to the Analyzer’s INPUT. Set the MODE switch to “VOLT” and adjust the oscillator output voltage to 7Vrms. Return the MODE switch to the “% DIST” position and check the Analyzer’s readings at the following frequency settings:

Settling time is typically less than 3 seconds from 50Hz to 1MHz. Longer at lower frequencies.

Oscillator Frequency	Analyzer Reading
1MHz	<0.4
500kHz	<0.2
100kHz	<0.02
10kHz	<0.008
1kHz	<0.005
100Hz	<0.005
10Hz	<0.008

3.2.3 ANALOG OUTPUT

The ANALOG OUTPUT is a dc voltage proportional to the percent distortion reading and is approximately 100mV/1%.

3.2.4 DISTORTION OUTPUT

The DISTORTION OUTPUT is a visual indication of the percent distortion displayed on the Analyzer's Digital Display Meter (DDM), and is approximately 100mV rms/% THD.

3.2.5 AC VOLTMETER CHECK

Set the Analyzer's MODE switch to "VOLT". Connect an ac standard to the Analyzer's INPUT and verify that the accuracy of the voltmeter is within $\pm 2\% \pm 1$ digit over the frequency range from 10Hz-500kHz and within $\pm 5\% \pm 1$ digit from 5Hz-1MHz.

3.2.6 OPTIONAL BCD OUTPUT CHECK

If the Analyzer is equipped with optional BCD Output, it may be checked by measuring the logic levels on the respective pins associated with each DDM reading in Figure 2.1 found in Section 2. A suggested method would be to set the Analyzer's MODE switch to "VOLT", and use the ac standard or facsimile to generate the respective digits.